



# ***Installation Instructions***

***Pipe Cradle***  
*Assembly, Installation & Operation*

***Scissor Lifts***

Part No. 72830GT

Rev E

July 2016

# Information

REV E

## Important

Read, understand and obey the safety rules and all instructions before using a pipe cradle. This manual is a part of your pipe cradle assembly kit and should remain with the pipe cradle assembly at all times. If you have any questions, contact Genie.

### Observe and Obey:

- Pipe cradle racks must be installed on the inside of the platform.
- Pipe cradle racks that are attached to the platform extension must be bolted to the extension railings only, not the platform railings.
- Pipe cradle racks must not obstruct the platform controls or the platform entry gate.
- The base of the pipe rack must rest on the platform deck.

**⚠WARNING** Do not install a pipe cradle assembly on any Scissor lift other than the designated models.

**⚠WARNING** Do not install a pipe cradle assembly on a GS-3246 before serial number 24439.

**⚠WARNING** Do not install a pipe cradle assembly on a GS-3384, GS-3390, GS-4390 or GS-5390 equipped with high flotation tires.

Note: Make sure you have the correct kit for your machine. If you have the incorrect kit or parts are missing from your kit, contact Genie.

**The pipe cradle assembly kits listed in this instruction manual are to be installed on the following machines only: GS-2046, GS-2646, GS-3246 (models after serial number 24438 only), GS-2668, GS-3268, GS-3384, GS-3390, GS-4390 and GS-5390.**

**Components Kit# 66172GT  
For use on the following models only:  
GS-2046, GS-2646 and GS-3246 with  
round railings**

Parts:	Part No.	Qty
Pipe Rack Base	66170GT	2
Pipe Rack Holder	66169GT	2
Pipe Rack Channel, 50 inches	66171GT	2
U-Bolt, Round, 3/8-16	66216GT	4
Screw, 3/8-16 x 2.75 inch	14033GT	8
Washers, Flat	6097GT	24
Nut, Nylock, 3/8-16	4828GT	16
Nylon Strap, 48 inches	35642GT	2
Strap Anchor	35644GT	2
Buckle, Side Release	35643GT	2
Decal, Warning Pipe Cradle	72864GT	2
Instruction Manual	72830GT	1

**Components Kit# 72878GT  
For use on the following models only:  
GS-2046, GS-2646 and GS-3246 with  
square railings**

Parts:	Part No.	Qty
Pipe Rack Base	66170GT	2
Pipe Rack Holder	66169GT	2
Pipe Rack Channel, 50 inches	66171GT	2
U-Bolt, Square, 3/8-16	66472GT	4
Screw, 3/8-16 x 2.75 inch	14033GT	8
Washers, Flat	6097GT	24
Nut, Nylock, 3/8-16	4828GT	16
Nylon Strap, 48 inches	35642GT	2
Strap Anchor	35644GT	2
Buckle, Side Release	35643GT	2
Decal, Warning Pipe Cradle	72864GT	2
Instruction Manual	72830GT	1

REV E

**Components Kit# 131626GT**  
**For use on the following models only:**  
**GS-2668, GS-3268, GS-2669, GS-3369 and**  
**GS-4069**

<b>Parts:</b>	<b>Part No.</b>	<b>Qty</b>
Instruction Manual	72830GT	1
Front Pipe Holder	66169GT	1
Rear Pipe Holder	79156GT	1
Pipe Cradle Tube	131622GT	2
Pipe Cradle Bracket	131625GT	4
U-Bolt, $\frac{3}{8}$ -16 x 2 x 3 inches	131681GT	4
Tube Plug	79355GT	4
Nut, Nylock, $\frac{3}{8}$ -16	4828GT	12
Washers, Flat	6097GT	16
Screw, $\frac{3}{8}$ -16 x 2.5 inches	8178GT	4
Nylon Strap, 48 inches	35642GT	2
Buckle, Side Release	35643GT	2
Strap Anchor	35644GT	2
Decal, Warning Pipe Cradle	72864GT	2

**Components Kit# 131627GT, V-shaped pipe**  
**cradle for use on the following models only:**  
**GS-3384, GS-3390, GS-4390 and GS-5390**

<b>Parts:</b>	<b>Part No.</b>	<b>Qty</b>
Instruction Manual	72830GT	1
Pipe Holder, V-shape	79352GT	2
Pipe Cradle Tube	131622GT	2
Pipe Cradle Bracket	131625GT	4
U-Bolt, $\frac{3}{8}$ -16 x 2 x 3 inches	131681GT	4
Tube Plug	79355GT	4
Nut, Nylock, $\frac{3}{8}$ -16	4828GT	12
Washers, Flat	6097GT	16
Screw, $\frac{3}{8}$ -16 x 2.5 inches	8178GT	4
Nylon Strap, 48 inches	35642GT	2
Buckle, Side Release	35643GT	2
Strap Anchor	35644GT	2
Decal, Warning Pipe Cradle	72976GT	2

**Components Kit# 131659GT, Square-shaped**  
**pipe cradle for use on the following models**  
**only: GS-3384, GS3390, GS-4390 and GS-5390**

<b>Parts:</b>	<b>Part No.</b>	<b>Qty</b>
Instruction Manual	72830GT	1
Pipe Holder, U-shape	99258GT	2
Pipe Cradle Tube	131622GT	2
Pipe Cradle Bracket	131625GT	4
U-Bolt, $\frac{3}{8}$ -16 x 2 x 3 inches	131681GT	4
Tube Plug	79355GT	4
Nut, Nylock, $\frac{3}{8}$ -16	4828GT	12
Washers, Flat	6097GT	16
Screw, $\frac{3}{8}$ -16 x 2.5 inches	8178GT	4
Nylon Strap, 48 inches	35642GT	2
Buckle, Side Release	35643GT	2
Strap Anchor	35644GT	2
Decal, Warning Pipe Cradle	72976GT	2

# Procedure

REV E

The pipe cradle assembly consists of 2 pipe racks positioned at the front and back of the Scissors platform.

## Pipe Cradle Assembly

- GS-2046, GS-2646 and GS-3246:** At the flat side of the pipe rack base, insert a bolt with a washer, into the mounting holes of the rack base.
- Install the pipe rack base, bolts and washers onto the open side of the pipe rack channel as shown below.
- Using a nylock nuts and washers, securely fasten the pipe rack base to the pipe rack channel. Torque to 31 ft-lbs / 42 Nm.
- At the formed end of the pipe holder, insert a bolt and washer into the mounting holes of the pipe holder.
- Install the pipe holder, bolt and washer onto the open side of the pipe rack channel as shown below.
- Using nylock nuts and washers, securely fasten the pipe holder to the pipe rack channel. Torque to 31 ft-lbs / 42 Nm. Proceed to step 22.
- GS-2668, GS-3268, GS-2669, GS-3369 and GS-4069:** Securely install the tube plugs onto the ends of the pipe cradle tubes.
- Working with the formed pipe holder, insert a bolt and washer into the mounting holes of the pipe holder.
- Using the illustration below as a guide, install the pipe holder, bolts and washers onto a pipe cradle tube as shown below.
- Using nylock nuts and washers, securely fasten the pipe holder to the pipe cradle tube. Torque to 31 ft-lbs / 42 Nm.
- Working with the flat pipe holder, insert a bolt and washer into the mounting holes of the pipe holder.
- Using the illustration below as a guide, install the pipe holder, bolts and washers onto a pipe cradle tube as shown below.
- Using nylock nuts and washers, securely fasten the pipe holder to the pipe cradle tube. Torque to 31 ft-lbs / 42 Nm. Proceed to step 27.

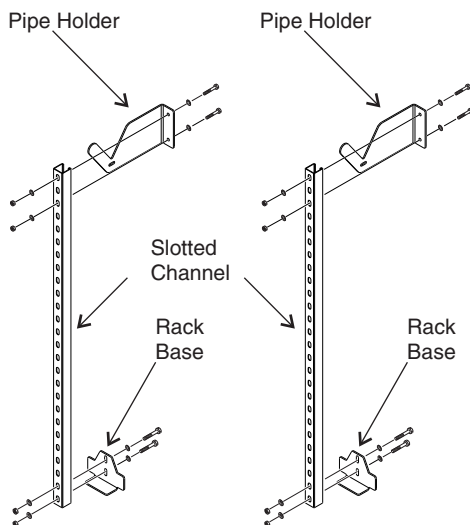

GS-2046, GS-2646 and GS-3246 Only

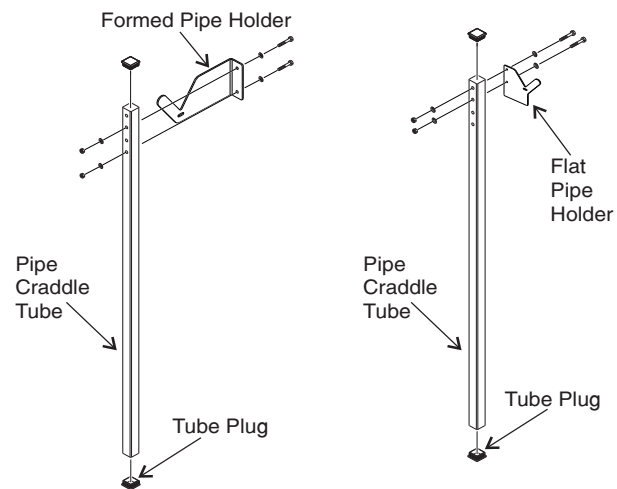

GS-2668, GS-3268, GS-2669,  
GS-3369 and GS-4069 Only

REV E

14 **GS-3384, GS-3390, GS-4390 and GS-5390 with a Single Extension Deck:** Securely install the tube plugs onto the ends of the pipe cradle tubes.

15 Working with the formed ends of the pipe holders, insert a bolt and washer into the mounting holes of the pipe holders.

16 Using the illustration below as a guide, install the pipe holder, bolts and washers onto the pipe cradle tubes as shown below.

Note: Observe the mounting locations of the extension deck pipe holder and the main deck pipe holder. The mounting locations are offset to compensate for the difference in deck height.

17 Using nylock nuts and washers, securely fasten the pipe holders to the pipe cradle tubes. Torque to 31 ft-lbs / 42 Nm. Proceed to step 34.

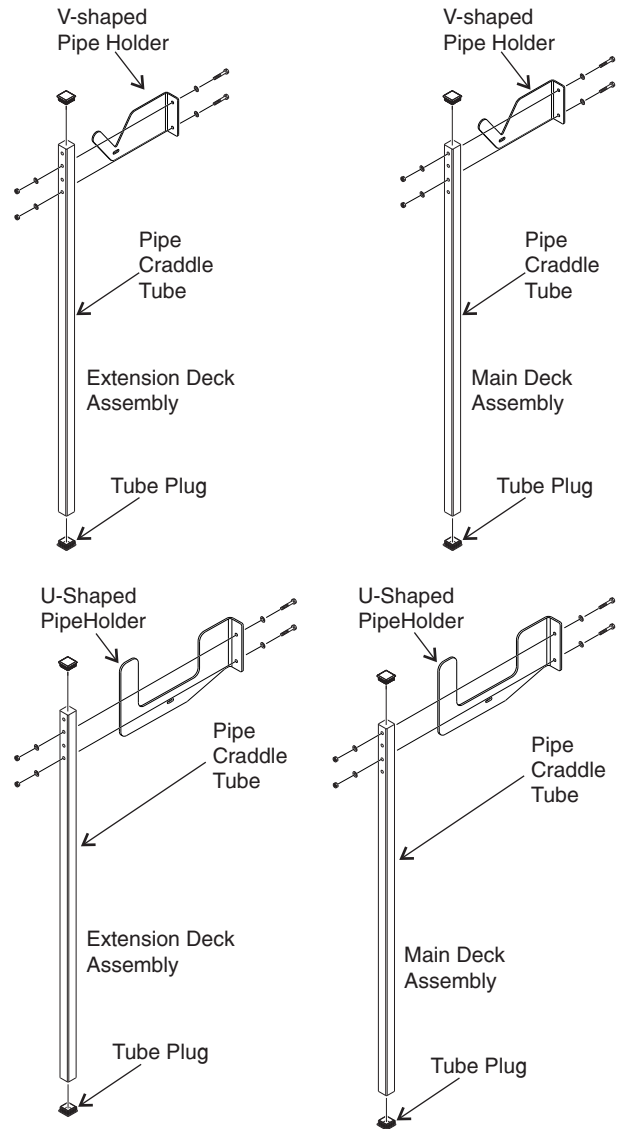

GS-3384, GS-3390, GS-4390 and GS-5390 with Single Deck Only

REV E

- 18 **GS-3384, GS-3390, GS-4390 and GS-5390 with Dual Extension Decks:** Securely install the tube plugs onto the ends of the pipe cradle tubes.
- 19 Working with the formed ends of the pipe holders, insert a bolt and washer into the mounting holes of the pipe holders.
- 20 Using the illustration below as a guide, install the pipe holder, bolts and washers onto the pipe cradle tubes as shown below.
- 21 Using nylock nuts and washers, securely fasten the pipe holders to the pipe cradle tubes. Torque to 31 ft-lbs / 42 Nm. Proceed to step 41.

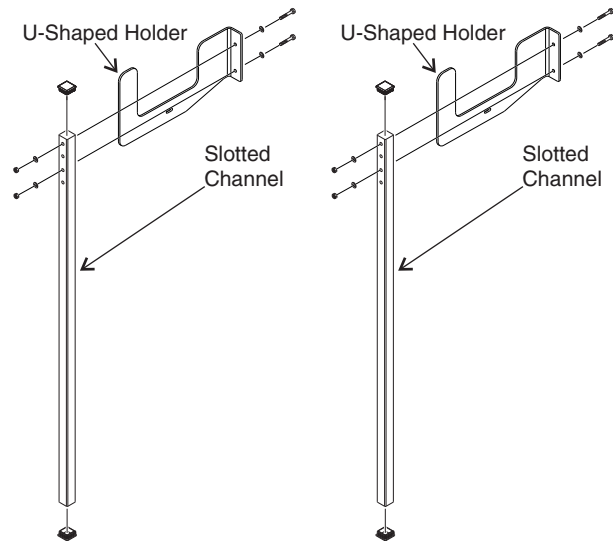
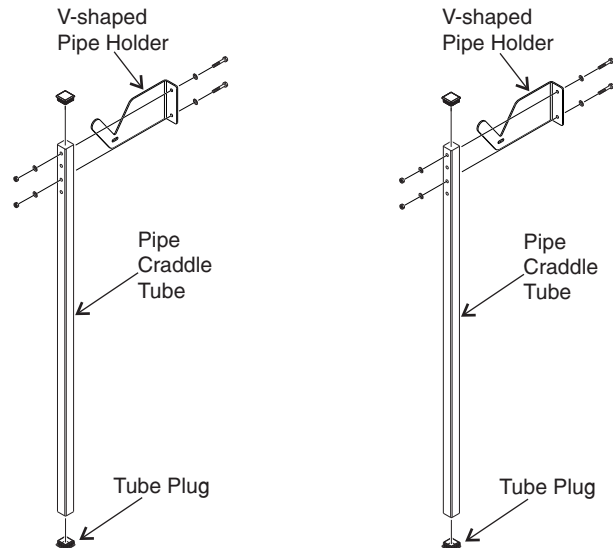

GS-3384, GS-3390, GS-4390 and GS-5390 with Dual Decks Only

REV E

PROCEDURE

## Pipe Cradle Installation

Note: Place the pipe cradles against the platform railings, facing into the platform.

Note: After installing the pipe cradles, do not attempt to move the extension deck into the stowed position. Before moving the extension deck into the stowed position, remove all material from the pipe cradles and remove the pipe cradle from the extension deck.

22 **GS-2046, GS-2646 and GS-3246:** Place both pipe cradle assemblies on the same side of the platform railing, approximately 24 inches / 610 mm from the front and back of the machine, with the base formings resting on the platform deck. Refer to Illustration 1.

23 Install a U-bolt around the upper platform railing or extension railing and insert the U-bolt ends into the nearest two slots in the pipe rack channel.

24 Install a second U-bolt around the lower platform railing and insert the U-bolt ends into the nearest two slots in the pipe rack channel.

25 Using nylock nuts and washers, securely fasten the U-bolts to the railings and the pipe rack channels. Torque to 31 ft-lbs / 42 Nm.

26 Pass a nylon strap through the slot in each pipe cradle assembly. Proceed to step 48.

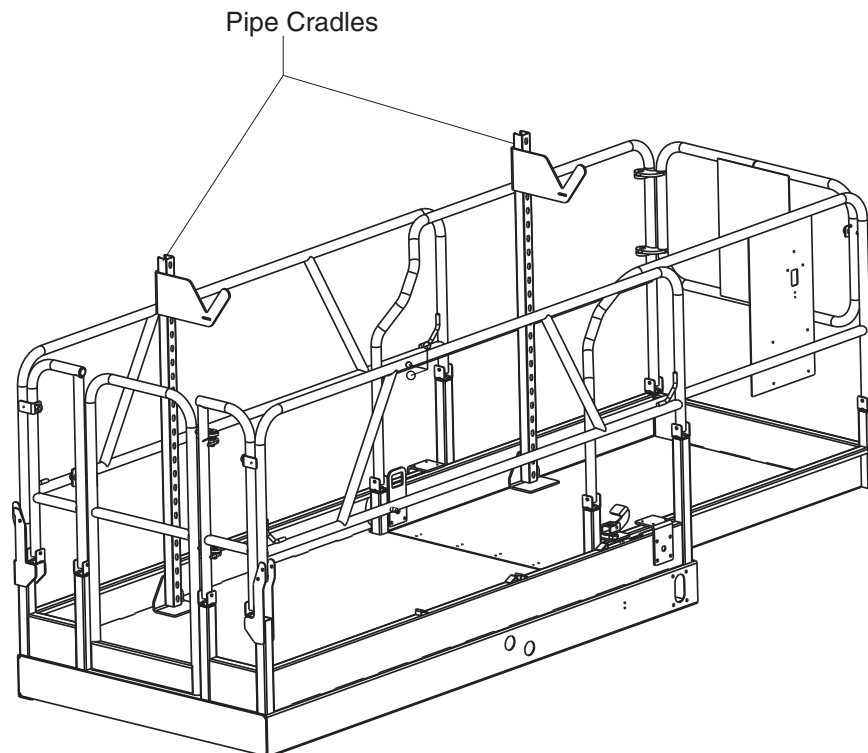

Illustration 1

## PROCEDURE

REV E

Note: After installing the pipe cradles, do not attempt to move the extension deck into the stowed position. Before moving the extension deck into the stowed position, remove all material from the pipe cradles and remove the pipe cradle from the extension deck.

- 27 **GS-2668, GS-3268, GS-2669, GS-3369 and GS-4069:** At the platform gate end, install a pipe cradle bracket onto the top platform railing and secure into place using a U-bolt and nylock nuts. Tighten the nuts to finger tight. Refer to Illustration 2.
- 28 Install a second pipe cradle bracket onto the lower platform railing and secure into place using a U-bolt and nylock nuts. Tighten the nuts to finger tight. Refer to Illustration 2.
- 29 Slide the pipe cradle assembly with the flat pipe holder through both pipe cradle brackets, making sure the end of the pipe cradle assembly is resting on the platform deck. Vertically align the pipe cradle assembly and torque the U-bolts to 31 ft-lbs / 42 Nm. Refer to Illustration 2.
- 30 At the extension deck, install a pipe cradle bracket onto the top platform railing and secure into place using a U-bolt and nylock nuts. Tighten the nuts to finger tight. Refer to Illustration 2.
- 31 Install a second pipe cradle bracket onto the lower extension deck railing and secure into place using a U-bolt and nylock nuts. Tighten the nuts to finger tight. Refer to Illustration 2.
- 32 Slide the pipe cradle assembly with the formed pipe holder through both pipe cradle brackets, making sure the end of the pipe cradle assembly is resting on the platform deck. Vertically align the pipe cradle assembly and torque the U-bolts to 31 ft-lbs / 42 Nm. Refer to Illustration 2.
- 33 Pass a nylon strap through the slot in each pipe cradle assembly. Proceed to step 48.

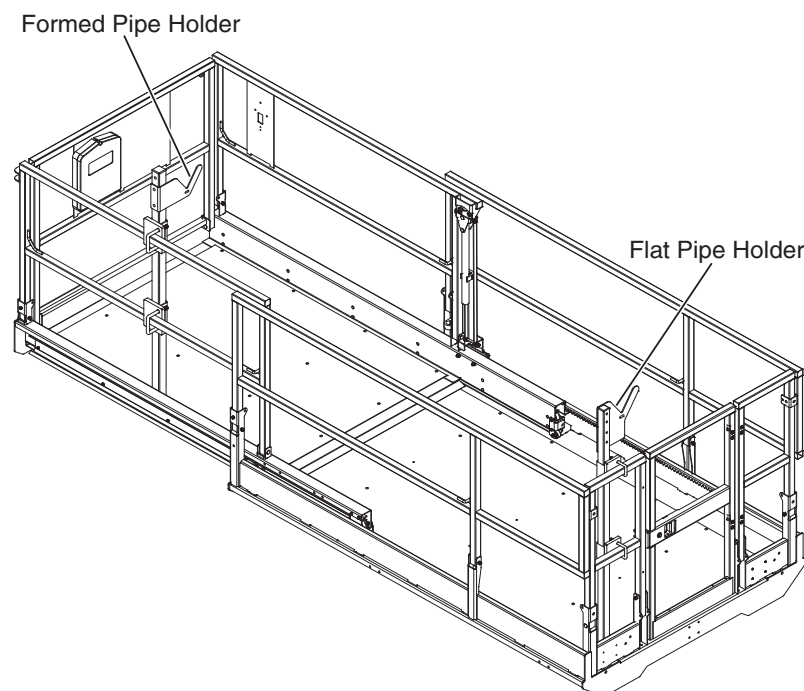

Illustration 2

**Genie**  
A TEREX COMPANY



REV E

PROCEDURE

Note: One of the platform entry gates must remain unobstructed when using the pipe cradle assembly. Do not attach any part of the pipe rack assembly to the platform entry gate.

Note: After installing the pipe cradles, do not attempt to move the extension deck into the stowed position. Before moving the extension deck into the stowed position, remove all material from the pipe cradles and remove the pipe cradle from the extension deck.

**34 GS-3384, GS-3390, GS-4390 and GS-5390 with a Single Extension Deck:** At the main deck, install a pipe cradle bracket onto the top platform railing and secure into place using a U-bolt and nylock nuts. Tighten the nuts to finger tight. Refer to Illustration 3.

**35** Install a second pipe cradle bracket onto the lower platform railing and secure into place using a U-bolt and nylock nuts. Tighten the nuts to finger tight. Refer to Illustration 3.

**36** Slide a pipe cradle assembly through both pipe cradle brackets, making sure the end of the pipe cradle assembly is resting on the platform deck. Vertically align the pipe cradle assembly and torque the U-bolts to 31 ft-lbs / 42 Nm. Refer to Illustration 3.

**37** At the extension deck, install a pipe cradle bracket onto the top platform railing and secure into place using a U-bolt and nylock nuts. Tighten the nuts to finger tight. Refer to Illustration 3.

**38** Install a second pipe cradle bracket onto the lower platform railing and secure into place using a U-bolt and nylock nuts. Tighten the nuts to finger tight. Refer to Illustration 3.

**39** Slide a pipe cradle assembly through both pipe cradle brackets, making sure the end of the pipe cradle assembly is resting on the platform deck. Vertically align the pipe cradle assembly and torque the U-bolts to 31 ft-lbs / 42 Nm. Refer to Illustration 3.

**40** Pass a nylon strap through the slot in each pipe cradle assembly. Proceed to step 48.

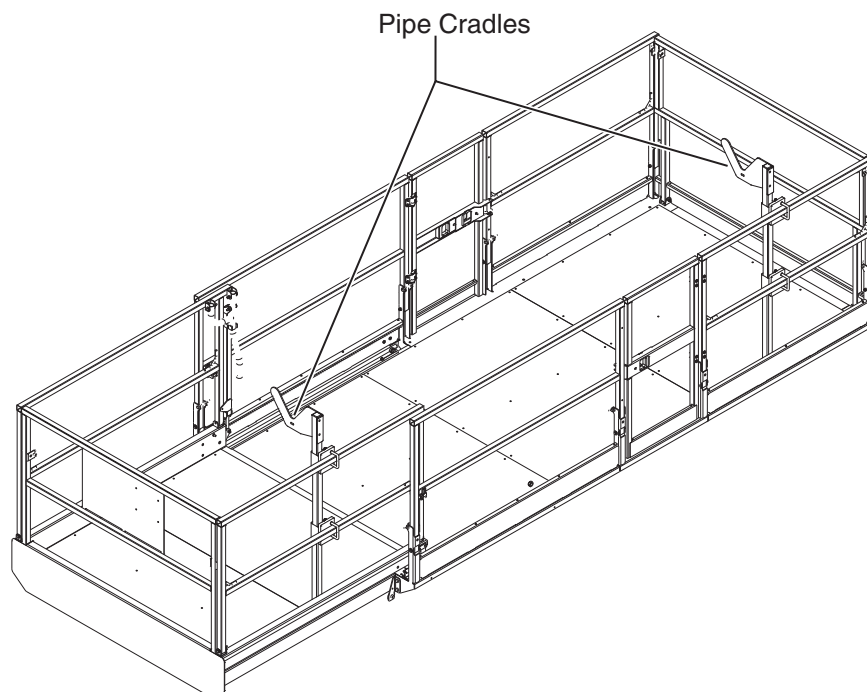

Illustration 3

**Genie**  
A TEREX COMPANY

REV E

Note: One of the platform entry gates must remain unobstructed when using the pipe cradle assembly. Do not attach any part of the pipe rack assembly to the platform entry gate.

Note: After installing the pipe cradles, do not attempt to move the extension decks into the stowed position. Before moving the extension decks into the stowed position, remove all material from the pipe cradles and remove the pipe cradles from the extension decks.

- 41 **GS-3384, GS-3390, GS-4390 and GS-5390 with Dual Extension Decks:** At the steer end extension deck, install a pipe cradle bracket onto the top platform railing and secure into place using a U-bolt and nylock nuts. Tighten the nuts to finger tight. Refer to Illustration 4.
- 42 Install a second pipe cradle bracket onto the lower platform railing and secure into place using a U-bolt and nylock nuts. Tighten the nuts to finger tight. Refer to Illustration 4.
- 43 Slide a pipe cradle assembly through both pipe cradle brackets, making sure the end of the pipe cradle assembly is resting on the platform deck. Vertically align the pipe cradle assembly and torque the U-bolts to 31 ft-lbs / 42 Nm. Refer to Illustration 4.
- 44 At the non-steer end extension deck, install a pipe cradle bracket onto the top platform railing and secure into place using a U-bolt and nylock nuts. Tighten the nuts to finger tight. Refer to Illustration 4.
- 45 Install a second pipe cradle bracket onto the lower platform railing and secure into place using a U-bolt and nylock nuts. Tighten the nuts to finger tight. Refer to Illustration 4.
- 46 Slide a pipe cradle assembly through both pipe cradle brackets, making sure the end of the pipe cradle assembly is resting on the platform deck. Vertically align the pipe cradle assembly and torque the U-bolts to 31 ft-lbs / 42 Nm. Refer to Illustration 4.
- 47 Pass a nylon strap through the slot in each pipe cradle assembly.

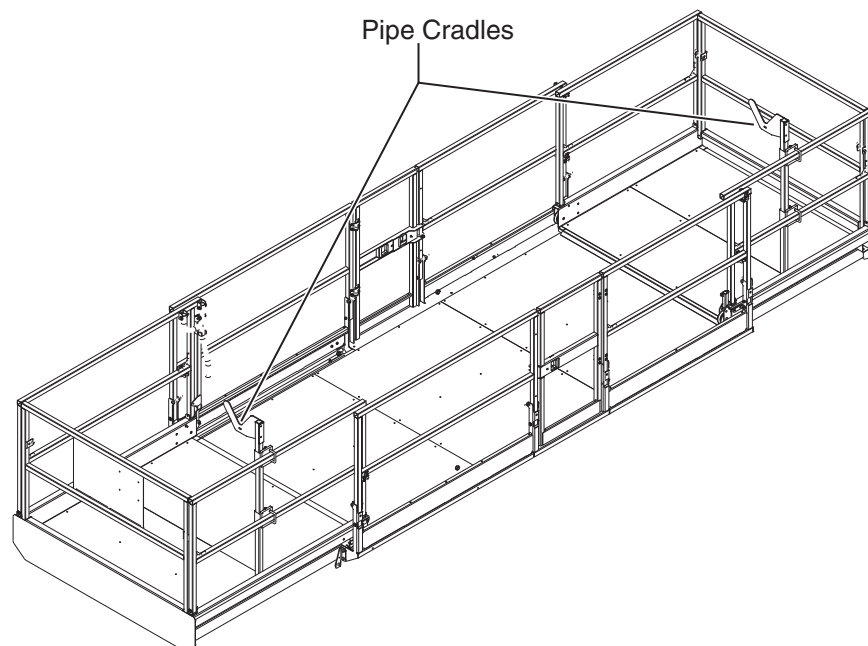

Illustration 4

REV E

## Operation

48 Be sure the pipe cradle assembly and installation instructions have been properly followed and the pipe racks are secured to the platform railings.

49 Place a load on the pipe holders and center the load.

Note: The load must rest on both pipe holders and the length of the load should be parallel with the length of the platform.

50 Secure the load to the platform. Pass the nylon strap over the load and clip the male strap connector to the female strap connector. Tighten the strap.

51 Gently push and pull on the load to ensure the pipe racks and load are secure.

Note: Always keep a load secured when the machine is moving.

**⚠WARNING** Tip-over hazard. The pipe cradle assembly and weight in the pipe cradles will reduce the rated platform capacity of the machine and must be factored into the total platform load.

### Pipe Cradle Capacity, Maximum

GS-2046, GS-2646, GS-3246	100 lbs	45 kg
GS-2668DC, GS-2668RT	100 lbs	45 kg
GS-3268DC, GS-3268RT	100 lbs	45 kg
GS-2669 / 3369 / 4069	100 lbs	45 kg
GS-3384, GS-3390, GS-4390	400 lbs	181 kg
GS-5390 without super deck	400 lbs	181 kg
GS-5390 with super deck	200 lbs	91 kg

### Pipe Cradle Assembly Weight

GS-2046, GS-2646, GS-3246	45 lbs	20.4 kg
GS-2668, GS-3268	45 lbs	20.4 kg
GS-2669 / 3369 / 4069	45 lbs	20.4 kg
GS-3384, GS-3390, GS-4390, GS-5390	57 lbs	26 kg

If you have any further questions regarding these instructions or need assistance, please contact Genie Product Support.